

19
23

19
23

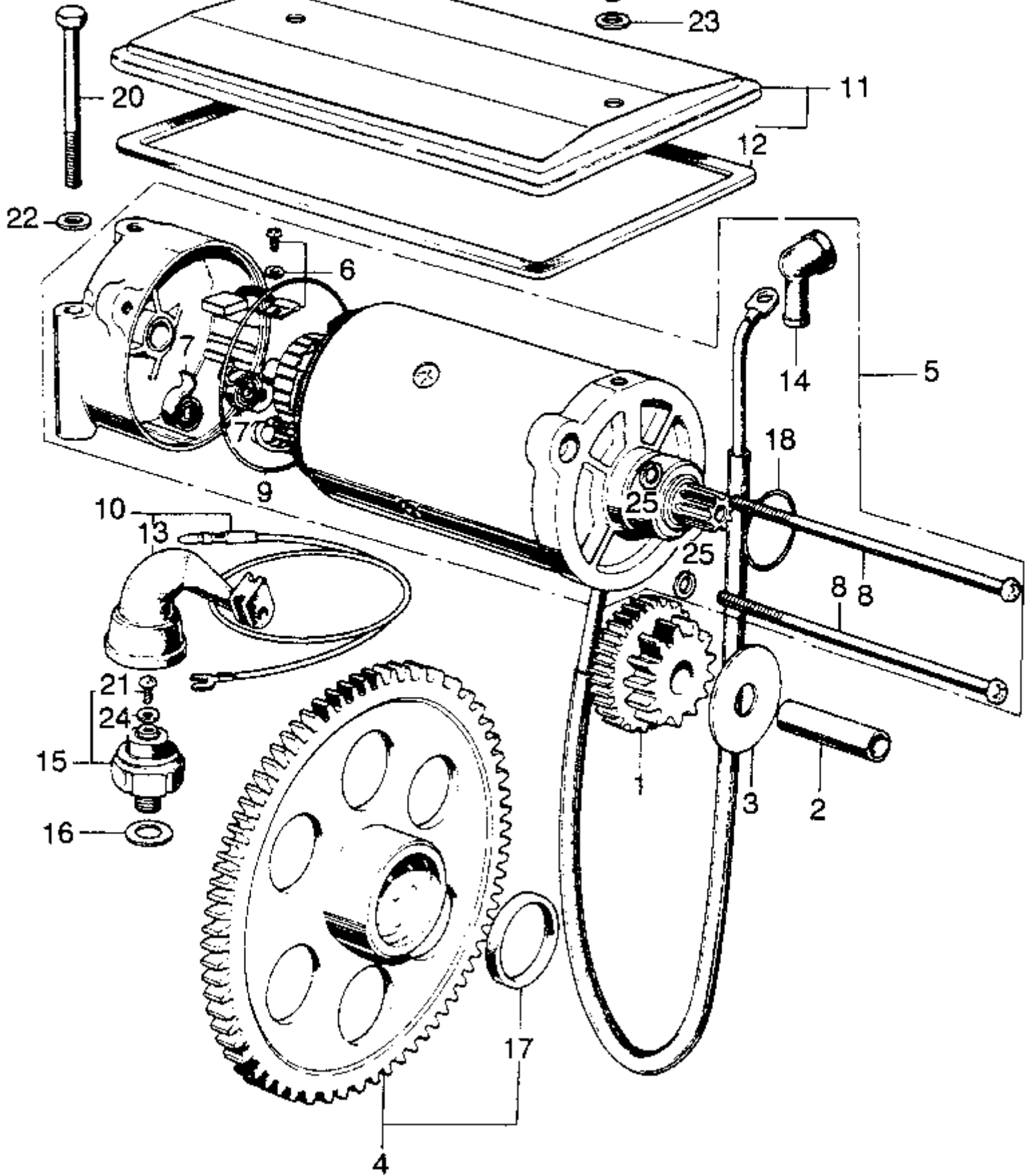

NUMBER	PART NAME-HONDA#	QTY NEEDED
01	GEAR 28101-300-000	001
02	SHAFT 28106-300-000	001
03	PLATE 28109-300-000	001
04	GEAR, STARTER CLUTCH 28110-300-000	001
05	STARTER MOTOR ASSY. 31200-300-030	001
06	BRUSH SET, CARBON 31201-292-158	001
07	SPRING, CARBON BRUSH 31204-292-158	002
08	BOLT, SETTING 31205-286-158	002
09	O-RING (60X1.4) 31206-402-008	001
09	O-RING (60X1.4) 31206-402-008	001
10	WIRE ASSY. 31270-300-154	001
11	COVER, STARTER MOTOR 31280-300-000	001
12	GSKT, START MTR CVR 31282-300-020	001
13	GROM, O/PRESS SW WR 31283-300-000	001
14	COVER 32411-230-000	001
14	COVER 32411-230-000	001
15	SWITCH, OIL PRESSURE 37240-P13-013	001
15	SWITCH, OIL PRESSURE 37240-P13-013	001
15	SWITCH, OIL PRESSURE 37240-P13-013	001
15	SWITCH, OIL PRESSURE 37240-P13-013	001
16	WASHER, OIL BOLT 90545-300-000	001
17	OIL SEAL (25X33X4) 91215-300-003	001
18	O-RING (24.4X3.1) 91312-MG7-003	001
18	O-RING (24.4X3.1) 91312-MG7-003	001
18	O-RING (24.4X3.1) 91312-MG7-003	001
19	BOLT, HEX. (6X8) 92101-06008-0B	002
19	BOLT, HEX. (6X12) 92101-06012-0B	002
19	BOLT, HEX. (6X8) 92101-06008-0B	002
19	BOLT, HEX. (6X8) 92101-06008-0B	002

19	BOLT, HEX. (6X12) 92101-06012-0B	002
20	BOLT, FLANGE (6X56) 95700-06056-00	002
20	BOLT, FLANGE (6X56) 95700-06056-00	002
21	SCREW, PAN (4X5) 93500-04005-0A	001
21	SCREW, PAN (4X6) 93500-04006-0A	001
21	SCREW, PAN (4X6) 93500-04006-0A	001
21	SCREW, PAN (4X6) 93500-04006-0A	001
23	WASHER, PLAIN (6MM) 94101-06200	002
24	WASHER, SPRING (4MM) 94111-04000	001
25	WASHER, SPRING (6MM) 94111-06000	002

www.hondachopper.com